

Medio Creek WRC Filter and UV System Improvements

Ila Drzymala, P.E.

SAWS - Project Engineer

Marisol V. Robles

SAWS - SMWVB Program Manager

Jonathan Miranda, MSJP

SAWS - Contract Administrator

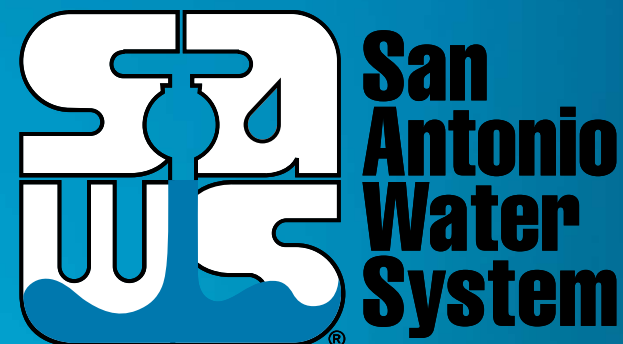

Pre-Bid Meeting
November 2, 2018

MAKING SAN ANTONIO
WATERFUL

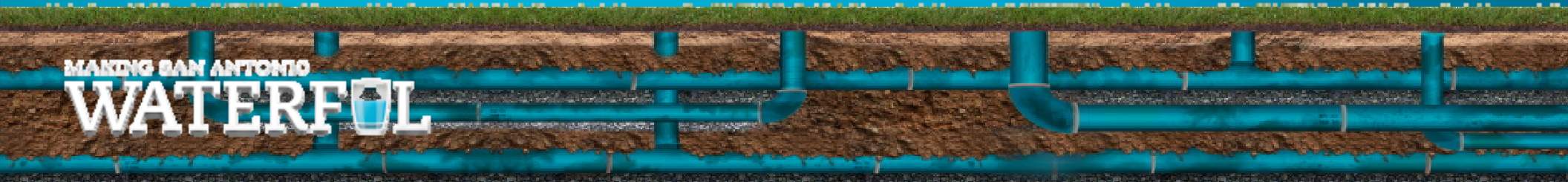

Oral Statements (Contracting)

- Oral statements or discussion during the pre-bid meeting today will not be binding, nor will it change or affect the terms or conditions within the Plans and Specifications of these Projects. Changes, if any, will be addressed in writing only via an Addendum.

Bid Overview

Medio Creek WRC Filter and UV System Improvements

CO-00226

Estimate: \$5,123,000.00

Calendar days: 300 days

Medio Creek WRC Filter and UV System Improvements

SMWVB Program Aspirational Goal

Industry	SMWVB Goal
Heavy Civil/Utility Construction	20%

Medio Creek WRC Filter and UV System Improvements



Accepted SMWVB Certifications

- Minority Business Enterprise (MBE)
- Small Business Enterprise (SBE)
- Woman-owned Business Enterprise (WBE)
- Veteran-owned Business Enterprise (Tracked)

Accepted SMWVB Certification Agency

- **South Central Texas Regional Certification Agency**
(Includes the Texas Historically Underutilized Business “HUB” Program)

Minimum Qualifications for SMWVB recognition:

- SBE-Certified (even MBEs and WBEs)
- **Local office or local equipment yard**

Good Faith Effort Plan (GFEP) FAQs

- **Q: Is the 20% SMWVB goal mandatory?**

A: No, but we ask prime consultants to do their best with good faith outreach efforts. If the goal is not met, proof of outreach efforts is required with the submittal.

- **Q: What if I am having trouble finding SMWVB subconsultants?**

A: Please email the SMWVB Program Manager with the scopes of work you are seeking. You will receive lists of local SMWVB-certified firms to contact.

- **Q: What if my business is SMWVB-certified? Do I need to find SMWVB subs?**

A: If your firm is SMWVB-certified, you will most likely meet the goal. However, the GFEP is a required document, and a good faith outreach effort is still necessary.

- **Q: What if I have questions about the GFEP?**

A: Please contact the SMWVB Program Manager at 210-233-3420, or at Marisol.Robles@saws.org. GFEP questions can be asked at any time before the submittal is due.

Post Award: Subcontractor Payment & Utilization Reporting (S.P.U.R.) System & Subcontractor Changes

WWW.SAWS.SMWBE.COM

The screenshot shows the homepage of the Subcontractor Payment & Utilization Reporting System. At the top left is the San Antonio Water System logo. To its right are links for 'OUR MAIN SITE' and 'CONTACT SUPPORT'. The main header features a large image of industrial water filtration equipment with the text 'Subcontractor Payment & Utilization Reporting System' and a 'Log In' button. Below this are three columns of navigation options: 'System Training' (Learn how to fully utilize our system with a live trainer), 'About the System' (Learn more about this system and how it works today), and 'Account Access' (Lookup Vendor accounts or reset user passwords). The 'Account Access' column contains two buttons: 'Account Lookup' and 'Forgot Password'. At the bottom, a footer states: 'The Subcontractor Payment & Utilization Reporting System is powered by i2Cizny Software © Copyright 2018.'

Medio Creek WRC Filter and UV System Improvements



Subcontractor Change Request

Any changes in subcontractors or suppliers requires prior approval from SAWS:

http://www.saws.org/business_center/contractsol/forms.cfm or

http://www.saws.org/business_center/contractsol/forms/SMWBChangeForm.pdf



Name of Contractor: _____
 Project Name & Number: _____

Submits the following approval request of the following addition(s) and/or deletion(s) on the Affirmed List of Subcontractors, as originally submitted as part of the BID/PROPOSAL/CONTRACT.

CHANGES

ADD	DELETE	NAME OF SUBCONTRACTOR	SBE, MBE, VBE, WBE	DESCRIPTION OF WORK TO BE PERFORMED	PERCENT & DOLLAR AMOUNT OF CONTRACT
<input type="checkbox"/>	<input type="checkbox"/>		▼		
<input type="checkbox"/>	<input type="checkbox"/>		▼		
<input type="checkbox"/>	<input type="checkbox"/>		▼		
<input type="checkbox"/>	<input type="checkbox"/>		▼		
<input type="checkbox"/>	<input type="checkbox"/>		▼		
<input type="checkbox"/>	<input type="checkbox"/>		▼		
<input type="checkbox"/>	<input type="checkbox"/>		▼		
<input type="checkbox"/>	<input type="checkbox"/>		▼		

JUSTIFICATION

AFFIRMATION

THE ABOVE IS TRUE AND COMPLETE TO THE BEST OF MY KNOWLEDGE AND BELIEF, I FURTHER UNDERSTAND AND AGREE THAT THIS DOCUMENT SHALL BE ATTACHED THERETO AND BECOME A BINDING PART OF THE CONTRACT.

Name & Title of Authorized Requestor: _____ Date: _____
 Signature of Authorized Requestor: _____

SMWB PROGRAM MANAGER: _____	DATE APPROVED: _____
CONTRACTING DIRECTOR: _____	DATE APPROVED: _____

Office Use Only: _____ S.P.U.R. System _____ CPMS _____ Project Hard File _____

Contract Requirements

Prevailing Wage Rate and Labor Standards – Section 2.10 of the General Conditions

- Certified payroll to be submitted on weekly basis
- Wage decisions are included within the specifications
- Contractors to utilize LCP Tracker
- Site visits are random and unannounced
- Interviews will be Conducted and will be private & confidential
- Payroll records are subject to review
- All apprenticeship programs will need to be approved by Department of Labor prior to starting
- Interviews will be Conducted and will be private & confidential
- Contractors are responsible for sub-contractor payroll
- Late payrolls delay contractor payments from SAWS

Contract Requirements (Continued)

- **Insurance** – Found in Section 5.7 of the General Conditions.
 - Insurance Requirements: Construction w/Pollution and Builder's Risk is Modified to Installation Floater is required.
 - Insurance must be compliant prior to executing the contract.
 - Selected contractor must be compliant with all other contracts in order for SAWWS to award the contract.
 - We will ask for insurance prior to Board award to expedite execution of the contract.

Bid Packet Preparation

- Utilize the Bid Packet Checklist within the specifications
- SAWS is requesting that the Statement of Bidder's Experience be completed and included by all bidders
- Double check all mathematical calculations and verify all extensions
- References and contact information must be verified prior to submitting bid(s)
- Addendums are now acknowledged on the Bid Proposals

Addendum(s)

Revisions, Clarifications, Questions and Answers (Q&A's)

- Questions deadline is on November 5, 2018 at 4:00 PM (CT).
- Q&A's will be posted on SAWS website on November 7, 2018 at 4:00 PM (CT).
- Check our website regularly for the addendum posting.
- It is possible to have multiple addenda during the time frame in addition to the scheduled final addendum.

Bid Opening Dates/Times

November 14, 2018 at 10:00 AM (CT)

- Bids may not be late
- Make arrangements if mailing and send directly to Contract Administration
- If delivering in person, bid packets will be turned in at Counter Services

Medio Creek WRC Filter and UV System Improvements



Key Reminders

- Questions regarding the SMWB Program, the Good Faith Effort Plan or any DBE forms, may be sent directly to SAWWS Program Manager, Marisol Robles up until the submission deadline.
- Please identify the project by its associated solicitation number.
- Contractors should not contact the SAWWS project engineer, the consultants for this project or any other SAWWS staff up until Board award.
- Late bids will not be accepted and will be returned unopened.
- If mailing bids, ensure that sufficient time is allowed for the package to reach SAWWS. If bids will be delivered in person to SAWWS, Respondents should allow sufficient travel time, as well as time to check in at the guard station.

Additional Reminders

- Please register through SAWS Vendor Registration Program on the SAWS website at www.saws.org to ensure access to the latest information.
- To receive updates on specific projects, registered vendors must 'Subscribe' to the project by selecting the project, and clicking 'Subscribe' under the Notify Me box.

contract solicitations
Invitation for Bid
Solicitation No. **CO-00157-JP** Job No. **17-5137 & 17-5617**

2018 Pipelines Water and Sewer Construction Contract Pkg I

Due Date: 10:00 AM Monday, 2/5/18 Estimated Cost: \$2,000,000.00
Status: Currently Accepting Submissions

Sealed bids are requested by the San Antonio Water System for the construction of approximately 5,900 LF of 6 to 8-inch of water main and approximately 3,000LF of 8-inch sewer main for the **2018 Pipelines Water and Sewer Construction Contract Pkg I**, SAWS Water Job No. **17-5137** and Sewer Job No. **17-5617**.

Notify Me
Receive updates for this IFB sent straight to your inbox.

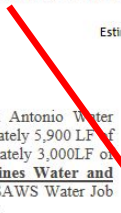

Medio Creek WRC Filter and UV System Improvements

POC and Technical Questions

Questions must be in writing and should be submitted no later than:
Monday, November 5, 2018 at 4:00 p.m. CST

**Contract Administration Department
San Antonio Water System**

Jonathan Miranda

Jonathan.Miranda@saws.org

Fax: (210) 233-4253

Medio Creek WRC Filter and UV System Improvements



Contact Information

<u>Contact Name</u>	<u>Title</u>	<u>Telephone Number</u>	<u>Email address</u>
Jonathan Miranda	Contract Administrator	210-233-3460	Jonathan.Miranda@saws.org
Marisol Robles	SMWVB Program Manager	210-233-3420	Marisol.Robles@saws.org

Medio Creek WRC Filter and UV System Improvements

Ila Drzymala, P.E.

SAWS - Project Engineer

Marisol V. Robles

SAWS - SMWVB Program Manager

Jonathan Miranda, MSJP

SAWS - Contract Administrator

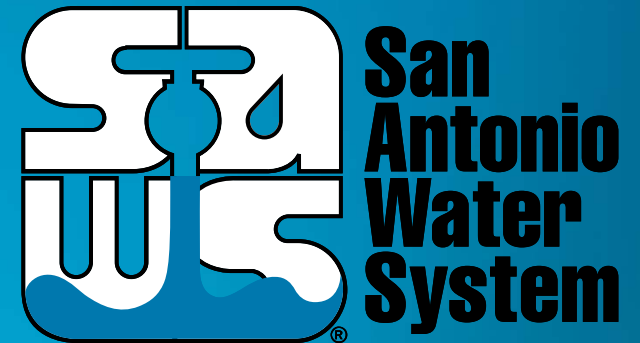

Pre-Bid Meeting
November 2, 2018

MAKING SAN ANTONIO
WATERFUL

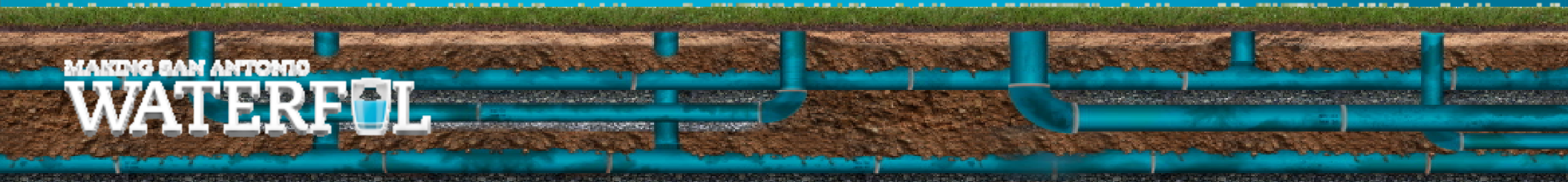

MEDIO CREEK WRC FILTER AND UV SYSTEM IMPROVEMENTS

Prebid Meeting

November 2, 2018

Scope

- Demolish existing filter complex mechanical components and appurtenances.
- Install new rotating cloth disc filters in existing filter basins.
- Provide temporary power to UV Units
- Remove existing UV units 1 at a time and replace with new.
- Electrical and Instrumentation upgrades

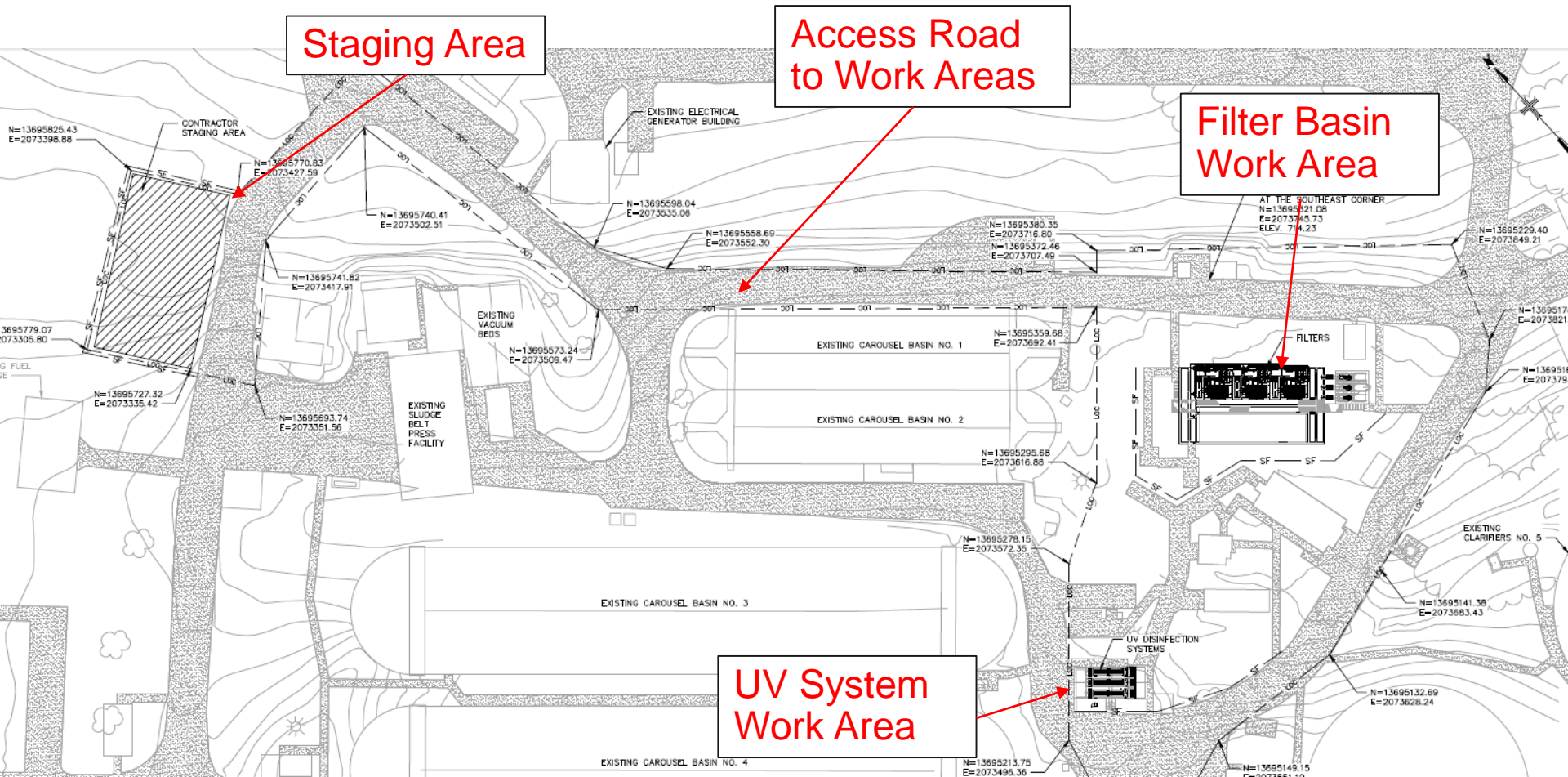

Demolition Work

- Salvage items listed on drawing D-01.
- All items removed/demolished are contractors responsibility to dispose of.
- All excavation materials are contractors responsibility to dispose of.
- Demolition items/materials should not remain on-site for extended period of time prior to being disposed of.

Filter Basin Work

- Remove all mechanical components and electrical for old sand filters
- Construct new walls and basins within complex
- Replace filter influent pumps and add a new one.
- Install new cloth disc filters.
- Construct new canopy over filter basin
- Startup and Testing

New pumps

New piping

**Three new filter modules
and basins**

New stairwells

**New filter influent
slide gates**

**Reuse existing
grating and railing
where possible.**

**New walkways
and walls**

New sluice gate

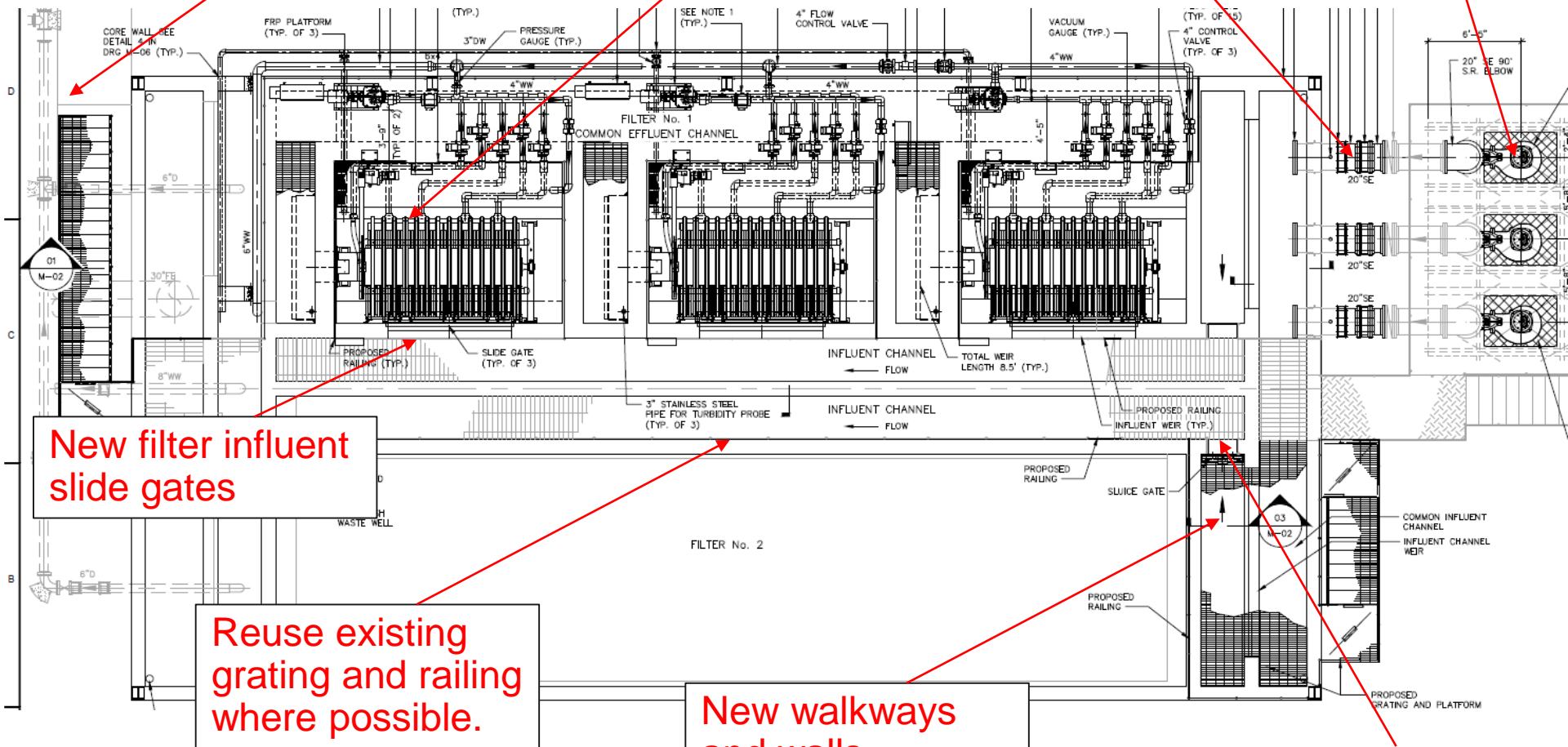

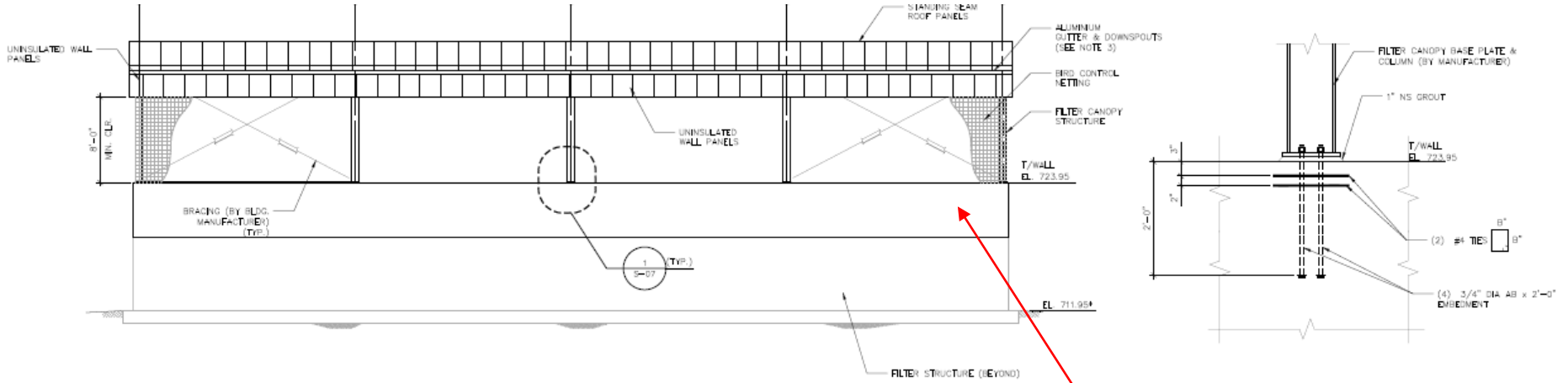

SOUTH ELEVATION
(NORTH ELEVATION OPP. HAND)
SCALE: 3/16" = 1'-0"
NOTE:
1. RAILING NOT SHOWN

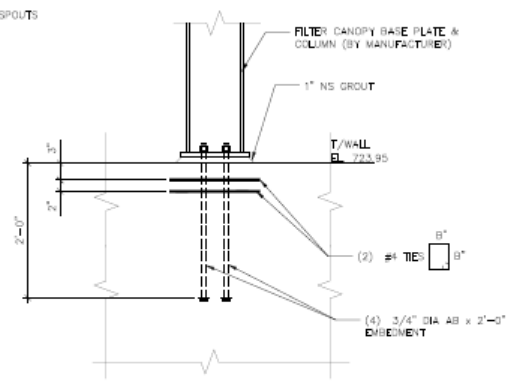

1 DETAIL
SCALE: 1" = 1'-0"

New canopy structure over filter

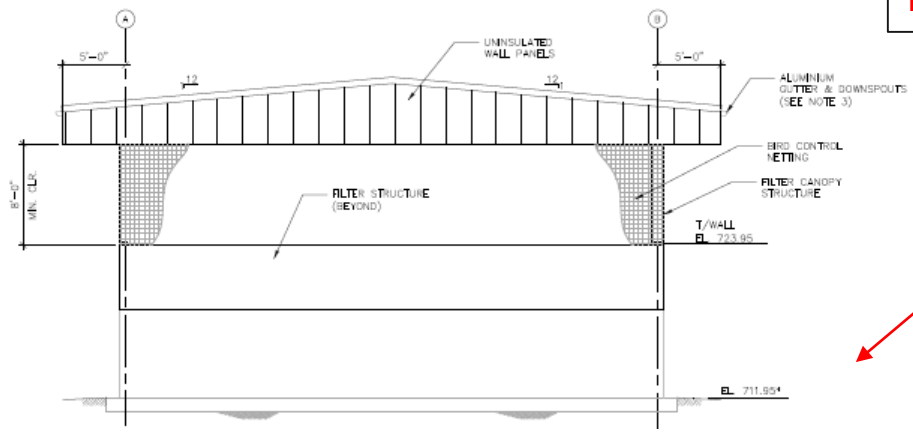

SHEET NOTES :
1. FILTER CANOPY STRUCTURE SHALL BE AS SPECIFIED IN

Structural Modifications

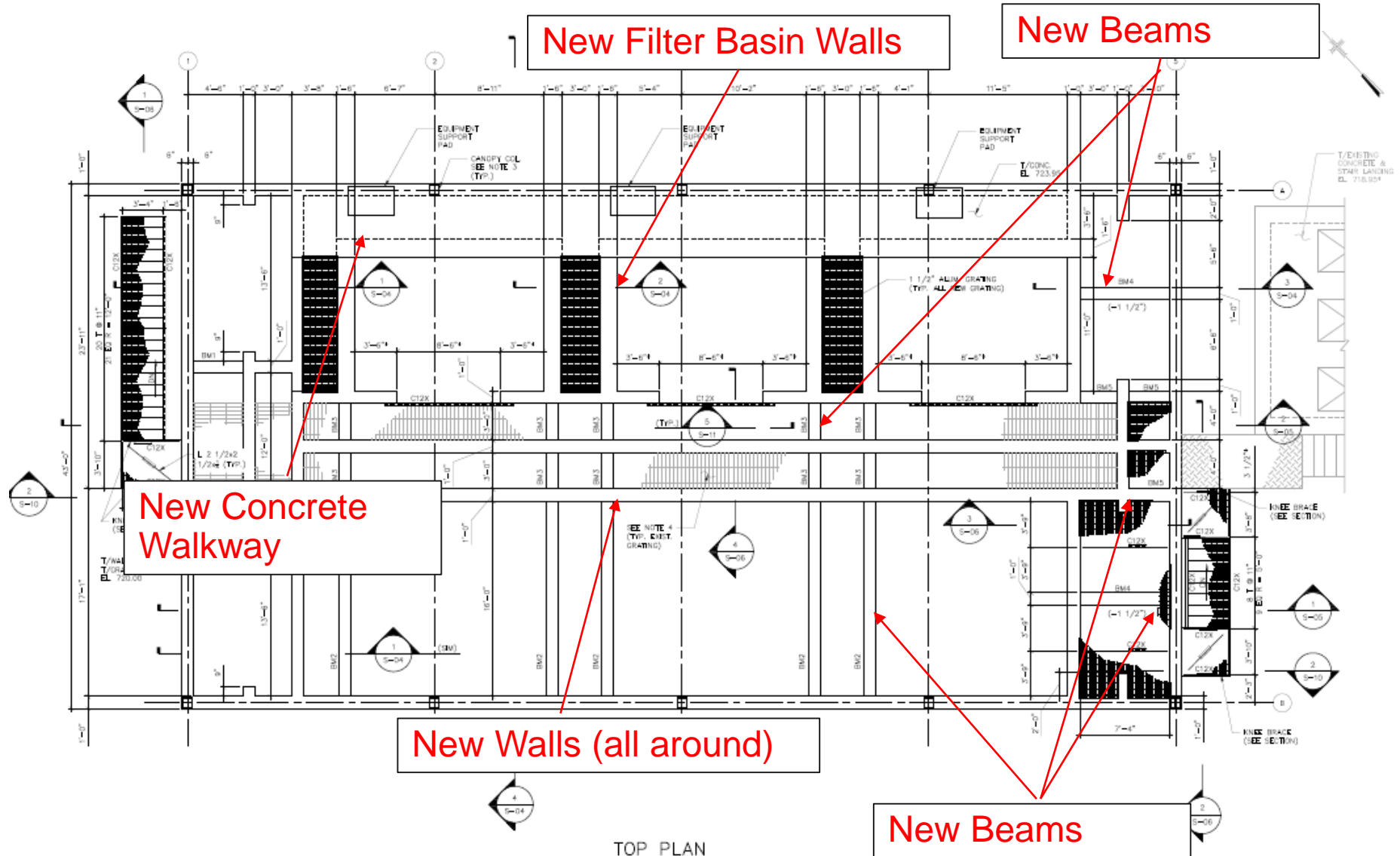

UV System Work

- Replace all three UV Units with new equipment
- Provide temporary power during construction duration to ensure at all times 2 UV Units are operational

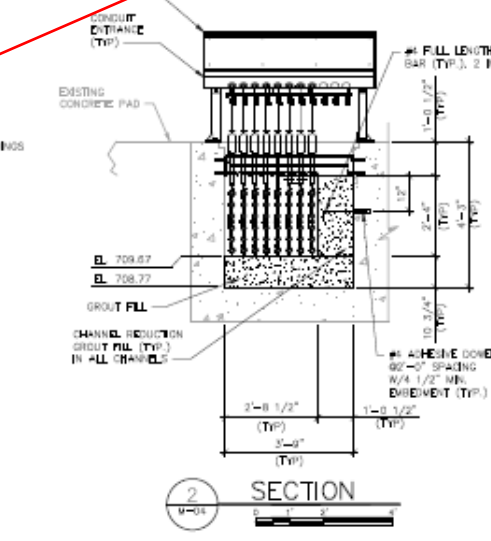
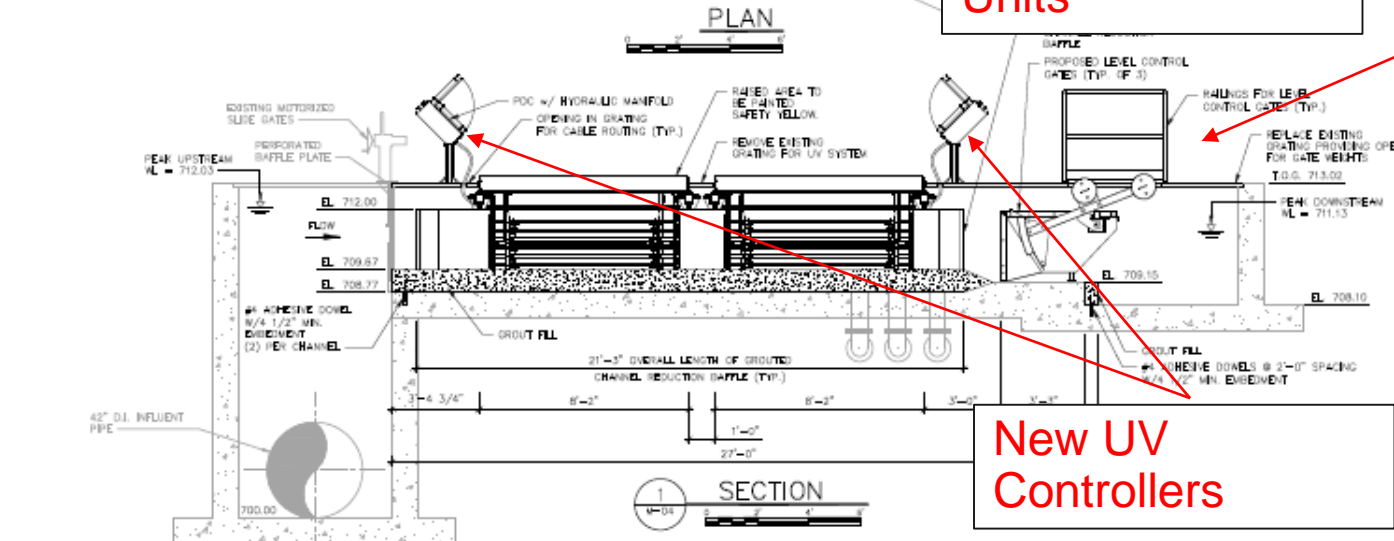
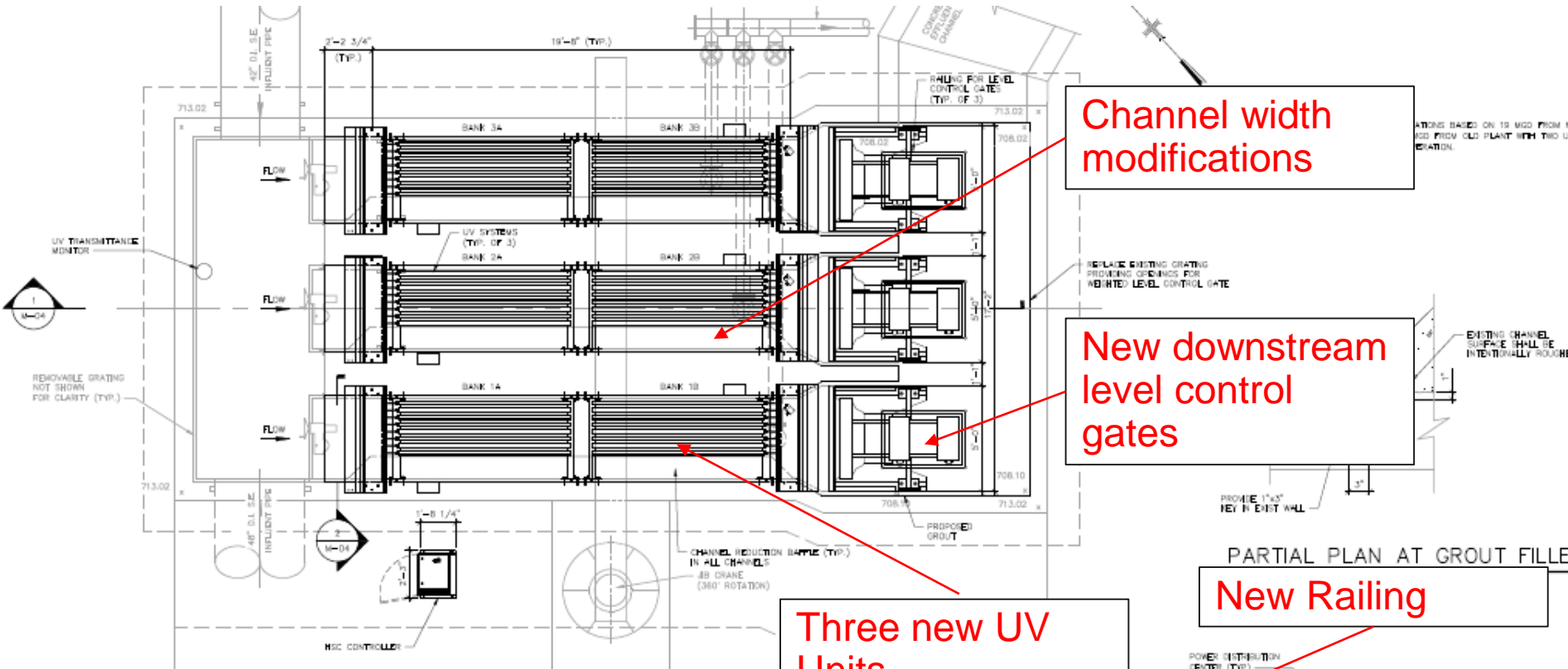

Sequence

- Detailed sequence of construction specified in Section 01 14 16, Coordination of Owners Operations. Must be followed.
- 2 UV Units must remain operational at all times, except for short period of time to hook up temporary power.
- UV System work must take place between months of July-August.
- Generators for temporary power shall be included in lump sum price for bid. Operational costs (fuel, maintenance, servicing etc.) for generator to be billed against allowance with receipts.

Schedule

- 300 Calendar days for construction
- UV System and Filters have a known lead time of 14-16 weeks after accepted submittal for delivery. Contractor should plan accordingly.

Permits and Special Inspections

- TCEQ Approval (Pending as of today)
 - No action required by Contractor
- CoSA Building Permit (Pending as of today)
 - Contractor shall be required to pick up permit once approved.
- Arcadis shall be special inspector for rebar and concrete. Contractor shall contact Arcadis in timely manner to plan inspections.

Emerson Cost

- Allowance provided for \$222,173.
- Bid provided as part of project manual documents.